



performance
that pays

Rotary Screw Compressors

UP5 Series 11-37 kW

performance **that pays**

Boost Your Profitability

Boosting your company's profits was the main goal that Ingersoll-Rand had in mind when designing the revolutionary UP-Series line of integrated rotary screw air solutions.

So how can a compressed air system help you increase profitability? The answer is really pretty simple, by ensuring that you achieve highest productivity in your shop while minimizing the total costs of ownership to the absolute lowest levels.

The UP-Series is more than an integrated air system, it's a complete air solution designed to maximize the key drivers of profitability in today's business:

- Ultimate Reliability
- Shop Productivity
- Flexibility Of Operation
- Energy Efficiency & Savings

Welcome to Ingersoll-Rand's UP-Series Rotary Air Solutions, a higher standard of performance.

Choosing the
right air solution
has never been
easier...

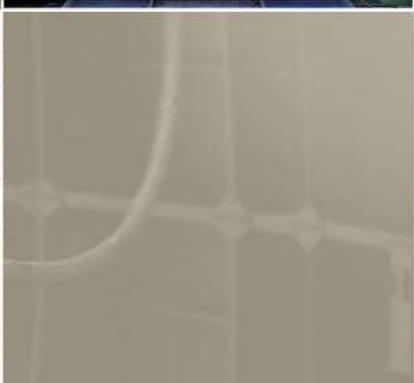

Exceptional **value**

Ultimate Reliability

- **Maximum Uptime**
Ingersoll-Rand is so confident in the performance of the UP-Series, that we've extended the warranty to 5 years.
- **Fewer Connections**
Smart integration eliminates leaks and pressure drops maximizing reliability.

Ultimate Efficiency

- **More Air For Your Money**
Industry leading performance delivers more air for less horsepower, saving thousands of Euros per year on energy.
- **Smart, Energy Efficient Controls**
Eliminates wasteful unloaded running by unloading rapidly and by cycling the compressor on/off when not needed.
- **Energy Efficiency**



High efficiency EFF1 IP55 enclosure main motor driving both compressor and cooling blower.

Ultimate Flexibility

- **Compact Footprint Design**
Receiver mounting frees up valuable floor space and reduces install costs.
- **Installation Close To Point-of-use**
Whisper quiet operation allows for installation closer to point-of-use, reducing costs and ensuring a better & safer work environment.



Ultimate Productivity

- **Closely Maintained Pressure**
Reduced discharge pressure and avoiding excessive pressure bands, increases downstream tool and equipment life.

Innovation

- **High Efficiency Integrated Compression Module**

To provide maximum performance, efficiency and ease of service, the airend, interconnecting piping and separation system have all been integrated into one simple design. Integration of the compression module eliminates leaks and pressure losses to increase efficiency and performance.

Service and maintenance are made extremely simple through spin-on filtration and separator cartridges.



Real world advantages

- **Whisper Quiet Operation**

Oversized, high efficiency cooling air blower. Provides sound levels as low as 67 dBA.



- **Dual Control Operation**

Reliable and effective load/no-load control with automatic stop and restart facility for maximum flexibility.



- **Simple Diagnostics**

Visual indication of operating status and hours run, for ease of operation and reduced downtime.



- **Poly-V Belt Drive**

Premium drive system applies patented automatic tensioning to eliminate belt stretch and increase air output.



- **Advanced Cooling**

A package prefilter, efficient combination aftercooler with access to both sides for easy cleaning and top discharge to simplify ducting.



- **Generous Serviceability**

All key maintenance components have been grouped to provide ease of serviceability.



Rotary Screw Compressors

UP5 Series 11-22 kW

ai

High Efficiency Filter Pack

Clean air to drive productivity

- Deep bed general purpose filtration to deliver best performance, reduce pressure losses and extend operating life.
- Particulate removal to industry leading 1 micron.
- Longer element life, lower pressure drop.
- Better air quality delivered to tools and equipment results in longer life, or ready for further treatment to meet specific requirements

Energy Savings Refrigerated Air Dryer

Dry air to drive productivity

- High efficiency direct expansion refrigerated dryer – automatically starts with the compressor and operates continually. This operating cycle ensures immediate drying, reactive to the compressor loads. The dryer operates until the compressor unit is shut down.
- Simple coiled tube-in-tube heat exchanger is selected at this size of unit to achieve optimum performance, with low losses, high thermal efficiency and long service life.
- Highly efficient centrifugal moisture separator with timed solenoid drain valve to permanently discharge condensate.
- Eliminates corrosion of piping, a cause of premature wear of tools and seals.

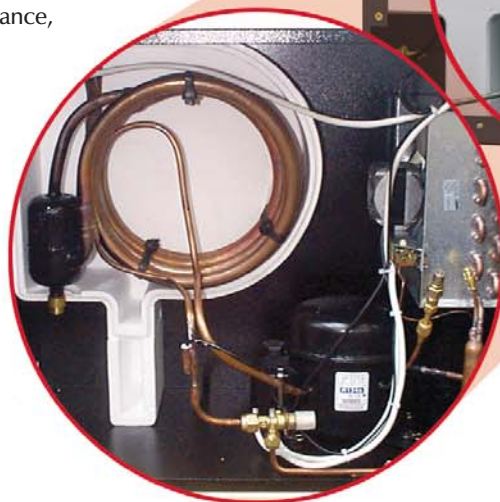
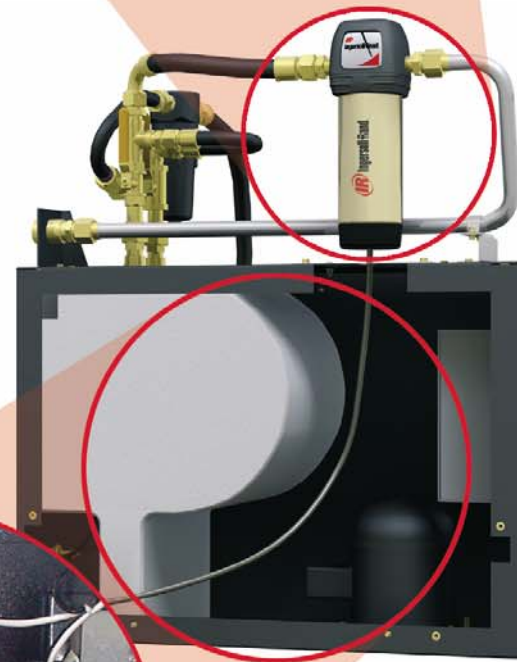

Integral Air Treatment

Smart Integration for 11-22 kW

Advanced packaging to drive reliability & uptime

- "Dry" Air Receiver mounted compact package lowers the cost of installation (optional floor mount also available).
- Integral air cooling with separate flow paths to ensure cooling is achieving 100% of time that compressor is running.
- Easy access to all compressor and air treatment components, promoting serviceability.
- Package pre-filter for longer component life and reduced maintenance cost.
- Simplified piping – elimination of potential leaks.
- Single point condensate drain system instead of separate points – reduces installation cost.
- Segregated cooling compartment provides advanced cooling flow management, and reduces noise level.

Practical Options and Kits

Customize your system

- Floor mounted
- Compressor package without air treatment equipment
- Weather resistant enclosure
- PORO (power outage restart option) to safely restore machine following power interruption
- Frost protection (not available for units with refrigerant dryer)
- Upper range modulation control
- Sequence controllers
- PacE system pressure regulators



Choosing the
right air solution
has never been
easier...

Rotary Screw Compressors

UP5 Series 22-37 kW

ai

Modular Cross Flow Heat Exchanger

Leading technology driving efficiency

At the heart of the dryer lies the specially designed cross flow heat exchanger module incorporating air-to-air and air-to-refrigerant heat exchangers, a high efficiency stainless steel de-mister condensate separator all in one compact unit.

Pre-cooling reduces the refrigeration load by as much as 60%. Air is further cooled through refrigerant heat exchange. Moisture is removed by the de-mister, close-coupled to the evaporator.

Cross flow heat exchanger incurs minimum air pressure losses while ensuring efficient water removal.

Energy Savings

Refrigerated Air Dryer

Dry air to drive productivity

- Direct expansion, refrigeration dryer simply and reliably dries the compressed air whenever the machine is loaded.
- Composite welded aluminium heat exchanger for low losses, high thermal efficiency and long service life.
- Solenoid drain valve and high efficiency moisture separator to permanently discharge condensate.
- Eliminates corrosion of piping, a cause of premature wear of tools and seals.

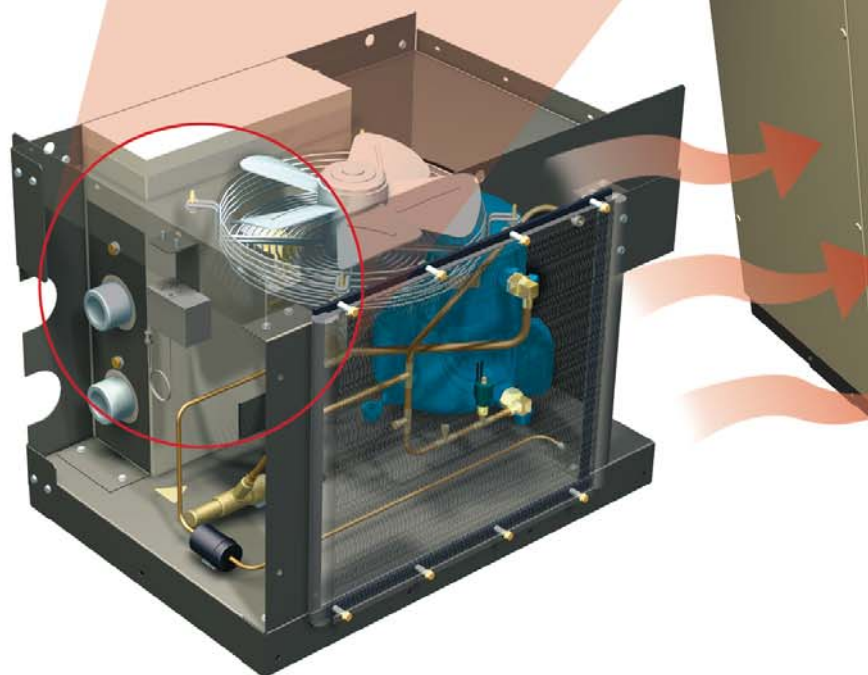
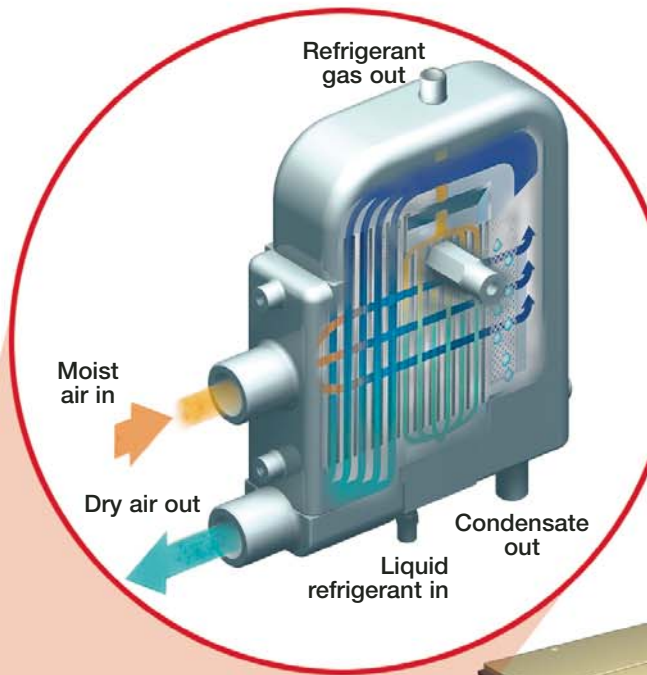

Integral r treatment

Smart Integration for 22, 30 & 37 kW

Advanced packaging to drive reliability & uptime

- Floor mounted units only (a wide range of free standing receivers are optionally available)
- Integrally cooled dryer module with separate cooling paths to achieve best overall efficiency and ensure cooling is achieving 100% of time that compressor is running.
- Spacious design simplifying access and promoting serviceability.
- Package pre-filter for longer cooler life and reduced maintenance costs.
- Simplified piping – elimination of potential leaks.
- Single point condensate drain system.
- Optional supply without dryer installation.

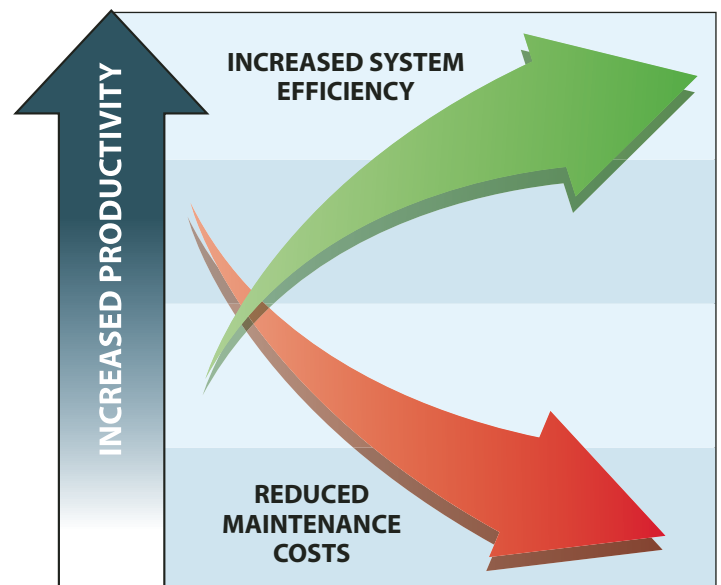

Choosing the
right air solution
has never been
easier...

Rotary Screw Compressors

UP5 Series 11-37 kW

Asset protection

Leading Warranty As Standard

- **5 Year Warranty Protection**

All Ingersoll-Rand UP-Series compressors come standard with a one year package warranty and a 4-year extended parts warranty coverage.



- **AirCare Coverage**

Ensure the highest level of satisfaction with the highly acclaimed, bumper-to-bumper, extended life care programme. Ask your authorized IR representative for more details.

Ultra-Plus Coolant

All units come standard with Ingersoll-Rand's Ultra-Plus advanced synthetic coolant:



- 9,000 hour extended coolant life
- Simple condensate separation
- High level of biodegradability

Ease Of Service

Ingersoll-Rand designed the UP-Series package with ease of service in mind. Spin-on filter and separator element along with 3/6/9,000 hour / annual service intervals make life simple. Your IR Air Solutions provider will recommend the most cost effective maintenance program to keep your investment operating trouble free for years.

Intellisys Control Option



Probably the best known name in compressor control systems, the optional intellisys control offers precise pressure control, energy saving functions and advanced asset protection.

Parts Kits Make It Simple

Simple to order parts kits make it easy to ensure that you have the right parts on hand when you need them. Ingersoll-Rand's reputation for compressor parts availability and reliability is second to none.

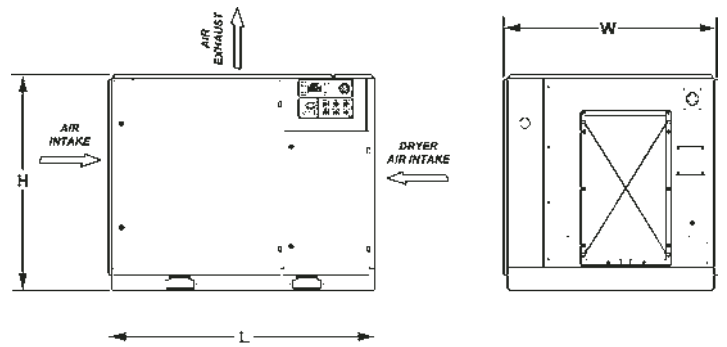
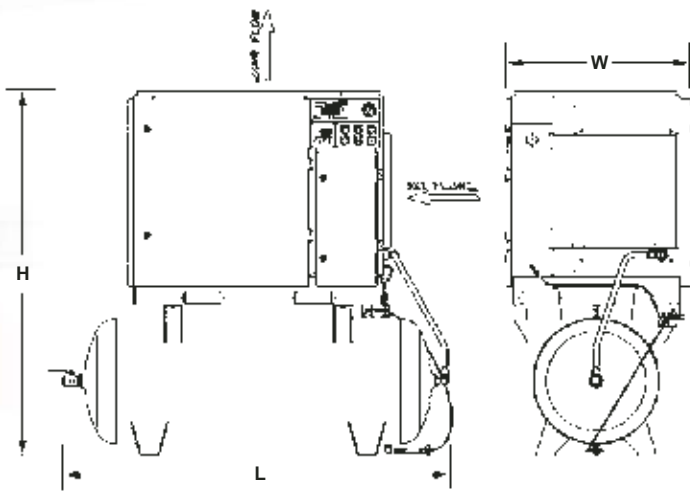

Industry Leading Performance

Specifications							
Model No	kW	HP	CAPACITY		Bar at discharge		dB(A) [†]
			m ³ /min ^{††}	(cfm) FAD	without dryer	with dryer	
UP5 11 7	11	15	1.84	65	7.5	7.15*	68+3
UP5 11 8	11	15	1.70	60	8.5	8.15*	68+3
UP5 11 10	11	15	1.54	54	10	9.65*	68+3
UP5 15 7	15	20	2.41	85	7.5	7.15*	68+3
UP5 15 8	15	20	2.36	83	8.5	8.15*	68+3
UP5 15 10	15	20	2.07	73	10	9.65*	68+3
UP5 15 14	15	20	1.61	57	14	13.65*	68+3
UP5 18 7	18.5	25	3.00	106	7.5	7.15*	68+3
UP5 18 8	18.5	25	2.87	101	8.5	8.15*	68+3
UP5 18 10	18.5	25	2.61	92	10	9.65*	68+3
UP5 18 14	18.5	25	2.01	71	14	13.65*	68+3
UP5 22 7	22	30	3.54	125	7.5	7.15*	69+3
UP5 22 8	22	30	3.34	118	8.5	8.15*	69+3
UP5 22 10	22	30	3.11	110	10	9.65*	69+3
UP5 22 14	22	30	2.32	82	14	13.65*	69+3
UP5 22E 7	22	30	3.95	140	7.5	7.3 [‡]	69+3
UP5 22E 8	22	30	3.70	131	8.5	8.3 [‡]	69+3
UP5 22E 10	22	30	3.35	118	10	9.8 [‡]	69+3
UP5 22E 14	22	30	2.75	97	14	N/A	69+3
UP5 30 7	30	40	5.40	191	7.5	7.3 [‡]	69+3
UP5 30 8	30	40	5.10	180	8.5	8.3 [‡]	69+3
UP5 30 10	30	40	4.80	169	10	9.8 [‡]	69+3
UP5 30 14	30	40	3.90	138	14	N/A	69+3
UP5 37PE 7	37	50	6.02	212	7.5	7.2 [‡]	69+3
UP5 37PE 8	37	50	5.89	208	8.5	8.2 [‡]	69+3
UP5 37PE 10	37	50	5.70	201	10	9.8 [‡]	69+3
UP5 37PE 14	37	50	4.73	167	14	N/A	69+3

* Maximum discharge pressure for package which includes moisture separator, refrigerated dryer and installation with GP filter. Filtration efficiency to 1 micron for solid particles, liquids 0.5 mg/m³ W at 21°C, and condensate drains.

‡ Maximum discharge pressure for package which includes moisture separator, refrigerated dryer, installation, and condensate drains.

Dimensions & Weights						
Mounting	kW	L	W (mm)	H	Package weight (kg)	
					without dryer	with dryer
Std	11	1285	920	1050	509	—
Baseplate	15	1285	920	1050	509	—
package	18	1285	920	1050	532	—
	22	1285	920	1050	540	—
	22E	1712	1379	1344	992	—
	30	1712	1379	1344	1028	—
	37	1712	1379	1344	1064	—
Baseplate	11	1702	920	1050	—	611
with Dryer	15	1702	920	1050	—	611
	18	1702	920	1050	—	643
	22	1702	920	1050	—	651
	22E	1712	1379	1344	—	1106
	30	1712	1379	1344	—	1142
	37	1712	1379	1344	—	1178
Tank-Mounted	11	2019	920	1757	730	832
500 litre	15	2019	920	1757	730	832
Receiver**	18	2019	920	1757	753	864
	22	2019	920	1757	761	872
Tank-Mounted	11	2132	920	1887	801	903
750 litre	15	2132	920	1887	801	903
Receiver**	18	2132	920	1887	824	935
	22	2132	920	1887	832	943

†† Capacity quoted tested in accordance with ISO 1217 annex C 1996 (CAGI-pneurop PN2CPT2)

** Dimensions same for receiver mounted package either with or without dryer.

† Sound levels per ISO 2151; 2004 annex C

N/A indicates not available



www.air.irco.com



TRYKLUFT CENTRET

Landsdækkende salg og service

Tlf.: 7022 1199 - E-mail: info@tcaa-trykluft.dk - www.tcaa-trykluft.dk



**Ingersoll-Rand
Industrial Air Solutions**
P.O. Box 1840
800-D Beaty Street
Davidson, NC 28036

**Ingersoll-Rand
Industrial Air Solutions**
Swan Lane
Hindley Green
Wigan, WN6 4EZ, UK

**Ingersoll-Rand
Asia Pacific**
c/o Ingersoll-Rand South East Asia (Pte) Ltd
42, Benoi Road
Singapore 629903